

Centre Number						Candidate Number				
Surname										
Other Names										
Candidate Signature										

For Examiner's Use	
Examiner's Initials	
Question	Mark
1	
2	
3	
4	
5	
6	
7	
TOTAL	



General Certificate of Education
Advanced Subsidiary Examination
January 2013

Physics A

PHYA2

Unit 2 Mechanics, Materials and Waves

Friday 18 January 2013 9.00 am to 10.15 am

For this paper you must have:

- a pencil and a ruler
- a calculator
- a Data and Formulae Booklet (enclosed).

Time allowed

- 1 hour 15 minutes.

Instructions

- Use black ink or black ball-point pen.
- Fill in the boxes at the top of this page.
- Answer **all** questions.
- You must answer the questions in the spaces provided. Do not write outside the box around each page or on a blank page.
- Do all rough work in this book. Cross through any work you do not want to be marked.
- Show all your working.

Information

- The marks for questions are shown in brackets.
- The maximum mark for this paper is 70.
- You are expected to use a calculator where appropriate.
- A *Data and Formulae Booklet* is provided as a loose insert.
- You will be marked on your ability to:
 - use good English
 - organise information clearly
 - use specialist vocabulary where appropriate.



J A N 1 3 P H Y A 2 0 1

Answer **all** questions in the spaces provided.

1 The world record for a high dive into deep water is 54 m.

1 (a) Calculate the loss in gravitational potential energy (gpe) of a diver of mass 65 kg falling through 54 m.

loss in gpe = J
(2 marks)

1 (b) Calculate the vertical velocity of the diver the instant before he enters the water. Ignore the effects of air resistance.

velocity = m s^{-1}
(2 marks)

1 (c) Calculate the time taken for the diver to fall 54 m. Ignore the effects of air resistance.

time = s
(2 marks)



1 (d) Explain, with reference to energy, why the velocity of the diver is independent of his mass if air resistance is insignificant.

.....

.....

.....

.....

.....

.....

(3 marks)

9

Turn over for the next question

Turn over ►



- 2 A snowboarder slides down a slope, as shown in **Figure 1**. Between **B** and **C** her acceleration is uniform.

Figure 1

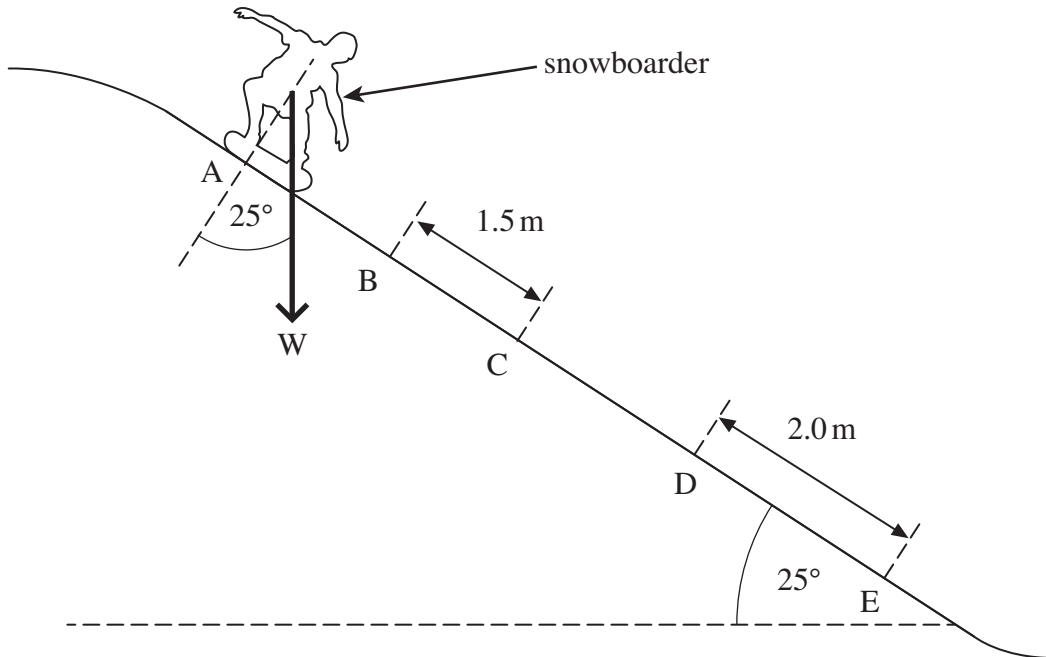

- 2 (a) The snowboarder travels 1.5 m from B to C in a time of 0.43 s and her velocity down the slope at C is 5.0 m s^{-1} .

Calculate her velocity down the slope at B.

velocity = m s^{-1}
(3 marks)

- 2 (b) The combined mass of the snowboarder and snowboard is 75 kg and the angle of the slope is 25° .

- 2 (b) (i) Calculate the component of the weight of the snowboarder and snowboard acting down the slope.

weight component = N
(2 marks)



2 (b) (ii) At D the snowboarder has reached a constant velocity. She moves a distance of 2.0 m at constant velocity between D and E.

Calculate the work done against resistive forces as she moves from D to E.

work done = J
(1 mark)

2 (c) State and explain what happens to the gravitational potential energy lost between D and E.

.....
.....
.....
.....
.....

(3 marks)

9

Turn over for the next question

Turn over ►



3 (a) State the principle of moments.

.....

.....

.....

.....

(3 marks)

3 (b) **Figure 2** shows a bicycle brake lever that has been pulled with a 35 N force to apply the brake.

Figure 2

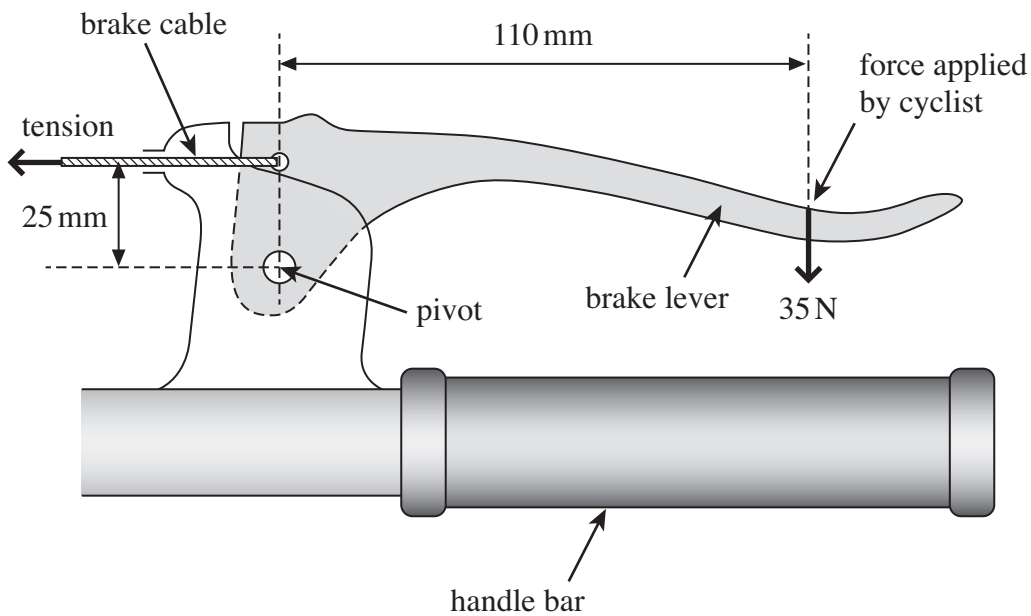

3 (b) (i) Calculate the moment of the force applied by the cyclist about the pivot. State an appropriate unit.

moment = unit (3 marks)



3 (b) (ii) Calculate the tension in the brake cable. Assume the weight of the lever is negligible.

tension = N
(3 marks)

3 (c) In order to maintain a constant velocity of 15 m s^{-1} downhill, the cyclist applies the brake. The power developed by the braking force is 2.8 kW.

Calculate the total average frictional force between the brake blocks and the wheel rim.

frictional force = N
(2 marks)

11

Turn over for the next question

Turn over ►



- 4 **Figure 3** shows a tower crane that has two identical steel cables. The length of each steel cable is 35 m from the jib to the hook.

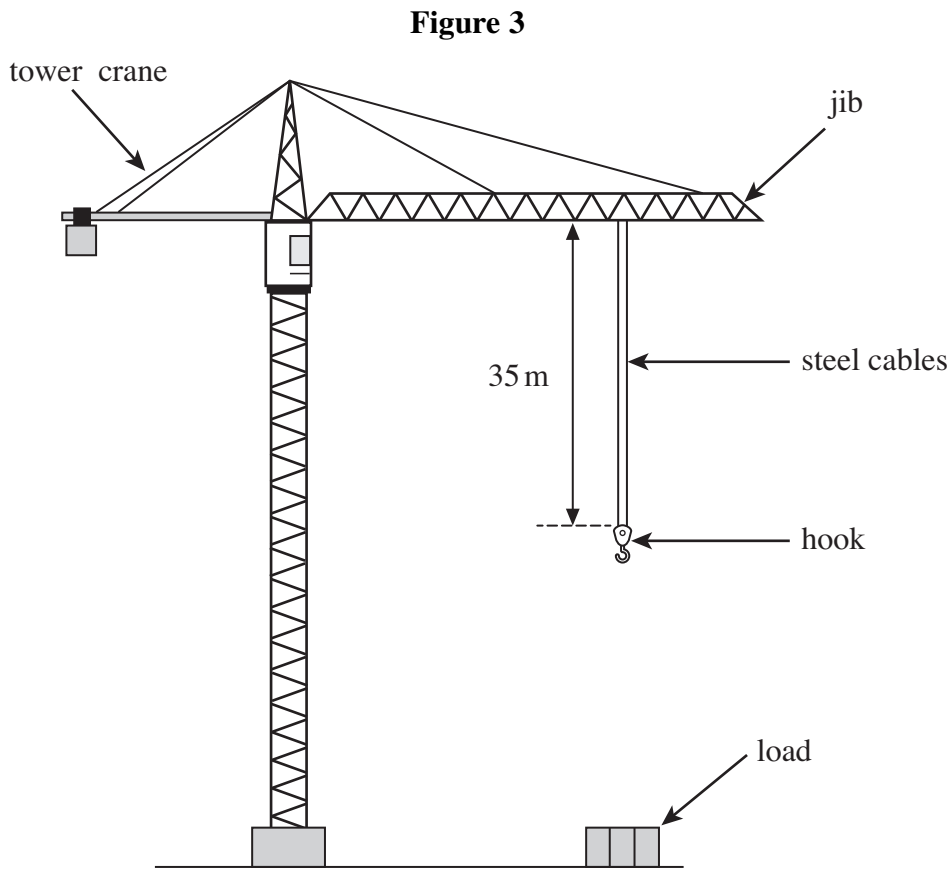

- 4 (a) Each cable has a mass of 4.8 kg per metre. Calculate the weight of a 35 m length of **one** cable.

weight = N
(2 marks)

- 4 (b) The cables would break if the crane attempted to lift a load of 1.5×10^6 N or more. Calculate the breaking stress of **one** cable.

cross-sectional area of each cable = 6.2×10^{-4} m²

breaking stress = Pa
(2 marks)



- 4 (c) When the crane supports a load **each** cable experiences a stress of 400 MPa. Each cable obeys Hooke's law. Ignore the weight of the cables.

Young modulus of steel = 2.1×10^{11} Pa

- 4 (c) (i) Calculate the weight of the load.

weight = N
(2 marks)

- 4 (c) (ii) The unstretched length of each cable is 35 m.

Calculate the extension of each cable when supporting the load.

extension = m
(3 marks)

- 4 (c) (iii) Calculate the combined stiffness constant, k , for the **two** cables.

stiffness constant = N m^{-1}
(2 marks)

- 4 (c) (iv) Calculate the total energy stored in both stretched cables.

energy stored = J
(2 marks)



5 **Figure 4** shows a section of a typical glass step-index optical fibre used for communications.

Figure 4

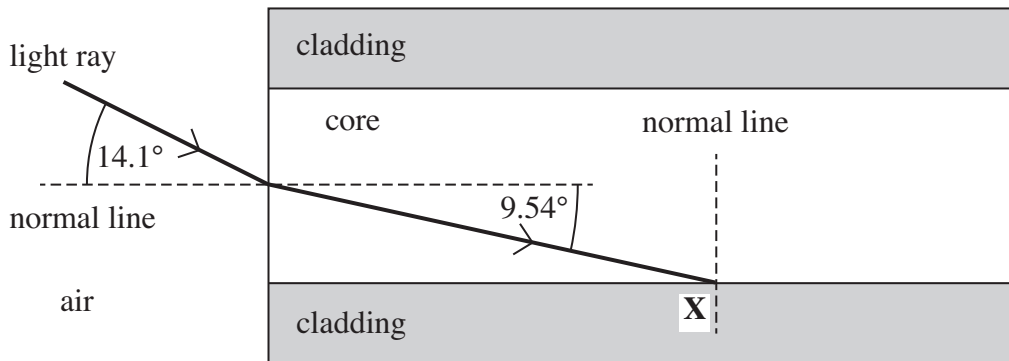

5 (a) Show that the refractive index of the core is 1.47.

(1 mark)

5 (b) The refracted ray meets the core-cladding boundary at an angle exactly equal to the critical angle.

5 (b) (i) Complete **Figure 4** to show what happens to the ray after it strikes the boundary at **X**.

(2 marks)

5 (b) (ii) Calculate the critical angle.

critical angle =degrees
(1 mark)



5 (b) (iii) Calculate the refractive index of the cladding.

refractive index =
(2 marks)

5 (c) Give **two** reasons why optical fibres used for communications have a cladding.

reason 1

.....

reason 2

.....

(2 marks)

8

Turn over for the next question

Turn over ►



7 **Figure 5** shows the paths of microwaves from two narrow slits, acting as coherent sources, through a vacuum to a detector.

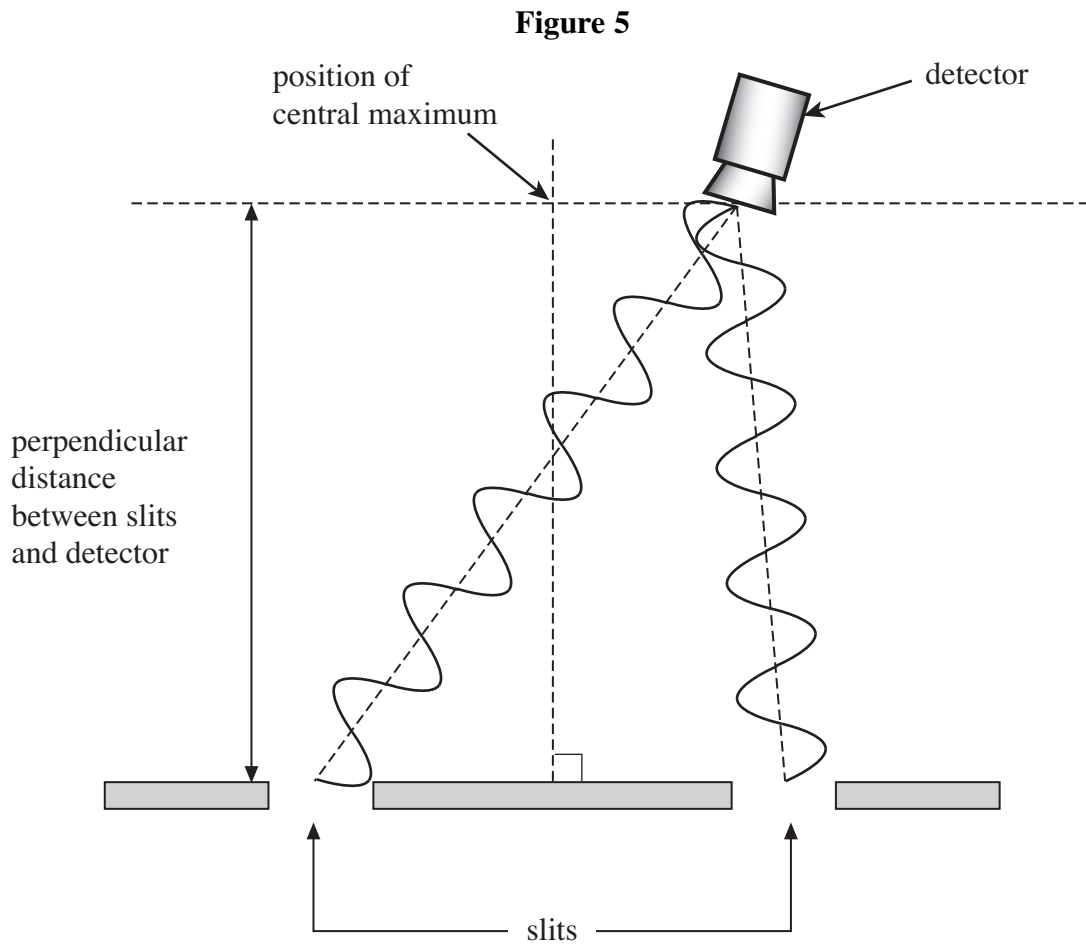

7 (a) Explain what is meant by *coherent sources*.

.....

.....

.....

.....

(2 marks)

7 (b) (i) The frequency of the microwaves is 9.4 GHz.

Calculate the wavelength of the waves.

wavelength = m
(2 marks)

Turn over ►



7 (b) (ii) Using **Figure 5** and your answer to part (b)(i), calculate the path difference between the two waves arriving at the detector.

path difference = m
(1 mark)

7 (c) State and explain whether a maximum or minimum is detected at the position shown in **Figure 5**.

.....
.....
.....
.....
(3 marks)

7 (d) The experiment is now rearranged so that the perpendicular distance from the slits to the detector is 0.42 m. The interference fringe spacing changes to 0.11 m.

Calculate the slit separation. Give your answer to an appropriate number of significant figures.

slit separation = m
(3 marks)

7 (e) With the detector at the position of a maximum, the frequency of the microwaves is now doubled. State and explain what would now be detected by the detector in the same position.

.....
.....
.....
.....
(3 marks)

END OF QUESTIONS



There are no questions printed on this page

**DO NOT WRITE ON THIS PAGE
ANSWER IN THE SPACES PROVIDED**



There are no questions printed on this page

**DO NOT WRITE ON THIS PAGE
ANSWER IN THE SPACES PROVIDED**

